

ledix

LED lighting fitting MUNA

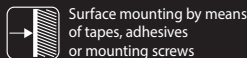

Surface mounting by means of tapes, adhesives or mounting screws



The fitting's protection level is suitable to be used outdoor



Mounting in a Ø60 junction box.

MUNA is a high quality LED fitting with decorative and application features. It is used for lighting corridors, passageways, for decorative lighting of furniture and lighting arrangement in the interior design.

The features of the fitting:

- easy mounting with a double-sided adhesive tape, glue or mounting screws (a dedicated mounting to the Ø60 junction box)
- protection degree IP44 allows for outdoor mounting
- luminous flux emitted in two planes: lower and front
- excellent lighting parameters obtained by applying the highest quality LED diodes by CREE
- repeatability of the light colour
- high lighting output with minimum power consumption
- high quality and durability estimated to light continuously for five years (~40 000 h).

CAUTION:

- Power supplies of ZNP and ZNN series and of ZNM series in 14 V DC version by Zamel are used to supply the fittings.
- Power supply should be adjusted to the number of powered fittings.
- The fitting with RGB diodes requires an additional, external RGB controller - it is recommended to use Zamel controllers with the following symbols SLR-11, SLR-12 and SLR-13.



Application:



stairs



corridors, passageways

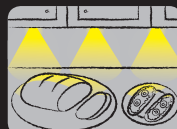

furniture, decorative lighting

zameL

14 V DC

LED lighting fitting MUNA

IP44

zameL

Zamel Sp. z o.o.

PL 43-200 Pszczyna, ul. Zielona 27, Poland
tel: +48 32 449 15 00, fax: +48 32 449 15 02
e-mail: ledix@ledix.pl, www.ledix.pl

14 V DC; IP44
weight: 108 g



Declaration of Conformity is on www.ledix.pl



The symbol means selective collecting of electrical and electronic equipment. It is forbidden to put the used equipment together with other waste.

02-111 ENG Ver. 01

www.ledix.pl

TECHNICAL DATA

Supply voltage	14 V DC	
Power consumption	0,56 W – cold white	
	0,42 W – warm white	
	0,28 W – red	
	0,28 W – green	
	0,28 W – blue	
	0,84 W – fitting with RGB LED diodes	
	cold white	warm white
Colour rendering index R_a	71	80
Colour temperature T_c [K]	5900	3100
Luminous flux Φ [lm]	18	12
Luminous efficiency [lm/W]	32	29

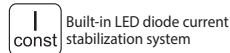
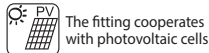
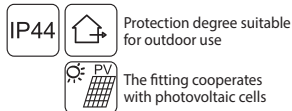

MOUNTING

The device is designed for single-phase installation and must be installed in accordance with standards valid in a particular country. Installation, connection and control should be carried out by a qualified electrician staff, who act in accordance with the service manual and the device functions.

MUNA fitting is designed for mounting by means of a double-sided adhesive tape, glue or mounting screws.

1. Disconnect power supply by the phase fuse, the circuit-breaker or the switch-disconnector combined to the proper circuit.
2. Check if there is no voltage on connection cables by means of a special measure equipment.
3. Connect the 14 V DC power supply to 230 V AC.
4. Connect the output cables of the power supply with the fitting cables with proper polarity (red wire of the fitting means „+“ power).
5. In case of a fitting with RGB LED diodes the power supply output cables should be connected to corresponding terminals of the RGB controller. The RGB fitting cables with proper sequence should be connected with the RGB controller.
6. In case of a double-sided adhesive tape:
 - a. prepare the surface for the fitting to be mounted - the surface must be clean and dry,
 - b. apply the adhesive tape or the mounting glue to the mounted fitting,
 - c. press the fitting to the base in the target mounting place paying attention that the fitting is mounted in accordance with the indicated direction - this will allow to provide the IP level guaranteed by the manufacturer.
- In case of mounting screws it is required:
 - d. remove the mounting element by sliding it down the fitting and holding it,
 - e. screw the mounting element in the target place or in $\varnothing 60$ junction box with mounting screws, in accordance with the indicated direction shown in the fitting,
 - f. put the fitting back on the mounting element.
8. Switch on the power supply from the mains.
9. Check if the fitting works properly.

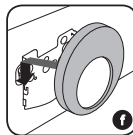
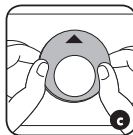
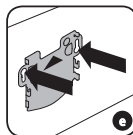
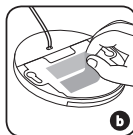

INSTALLATION EXAMPLE

MUNA fitting – single colour LED diodes

Figure 1. Fittings connected in a parallel way. The power supply is chosen according to the number of fittings.

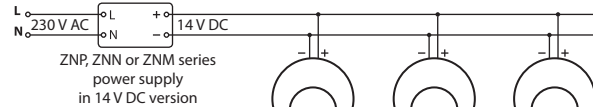
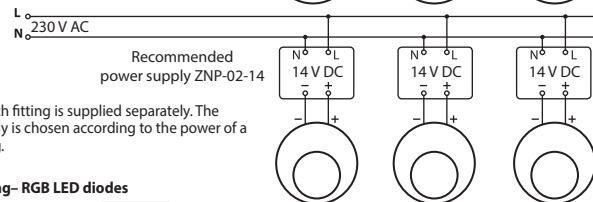

Figure 2. Each fitting is supplied separately. The power supply is chosen according to the power of a single fitting.



MUNA fitting – RGB LED diodes

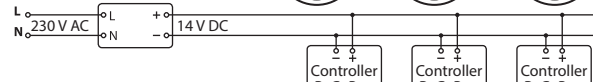

Figure 3. Each fitting is connected to a separate RGB controller. Possibility of connection to a typical 2-wire installation.

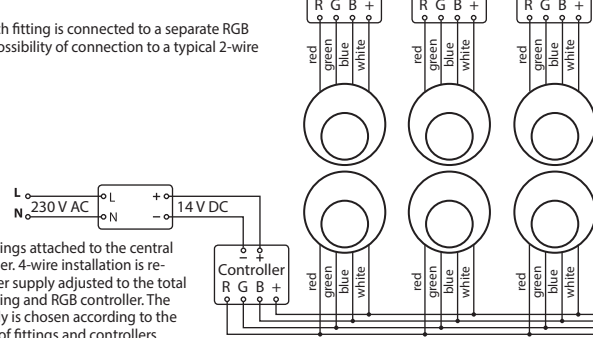

Figure 4. Fittings attached to the central RGB controller. 4-wire installation is required. Power supply adjusted to the total power of fitting and RGB controller. The power supply is chosen according to the total power of fittings and controllers.

CAUTIONS

- 14 V DC power supplies from the Zamel product offer (ZNP, ZNN, ZNM series) should be used to supply the fittings.
- Power supply must be chosen according to the amount of fittings and the way of their installation.
- The light source in fittings is not replaceable - if damaged, replace the entire fitting.
- In case of fittings with standard light colours, the red wire means „+“ power.
- Fittings with RGB LED diodes require an additional external RGB controller.
- One central RGB controller can be used for a few fittings (4 - wire installation) or a separate controller for each fitting (2 - wire installation).
- In case of RGB controllers, it is recommended to use the controllers from the Zamel product offer with the following symbols SLR-11, SLR-12, SLR-13.
- The manufacturer is not liable for damage caused by improper installation and use of the product.