

Project :

Date :

Cat. No. :

Type :

Notes :

Volts :

This power supply is a constant voltage for indoor and outdoor applications. Its aluminium case make this device an excellent choice for industrial and domestic applications. It comes with a junction box

<b>HOUSING MATERIAL</b>	: Aluminium
<b>IP RATING</b>	: IP66
<b>POWER FACTOR</b>	: ≥0,65
<b>EFFICIENCY</b>	: 83%
<b>OUTPUT CURRENT</b>	: 12V 8.33A - 24V 4,16A
<b>INPUT VOLTAGE</b>	: 100-130VAC
<b>VOLTAGE OUT</b>	: 12V or 24V
<b>OUTPUT POWER</b>	: 100W
<b>PROTECTION</b>	: Over current (1,2x output) /Short circuit overloading over temperature (100°C / auto recovery when temperature drops off
<b>WORKING HUMIDITY</b>	: 20%-90%
<b>DIMMING</b>	: Triac , flicker free dimming
<b>LOADING</b>	: 5% to 100%
<b>CERTIFICATION</b>	: ETL listed, UL1012



Dimensions (LxWxH): 230 x 70 x 46mm  
Net weight: 1.2Kg

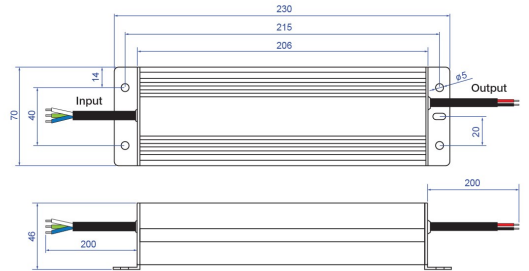

### CONNECTIONS:

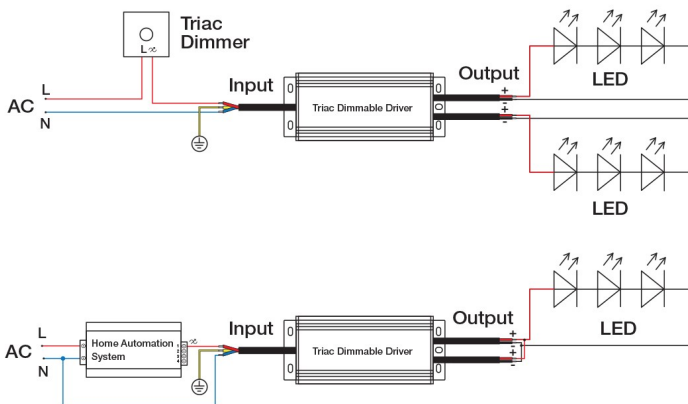

Dimensions (LxWxH): 380 x 77 x 57mm  
Net weight: 1.75Kg

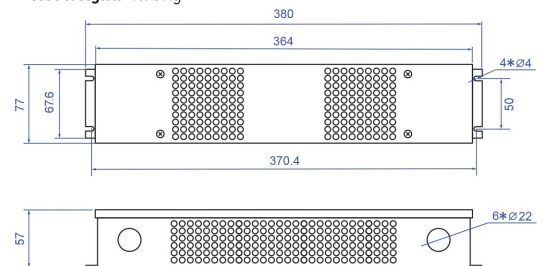

### Natech Industrie

3154 boulevard Industriel, Laval, QC, H7L 4P7 T: (450) 629-1169, F: (450) 629-1168, [www.natechlighting.com](http://www.natechlighting.com), [info@natechlighting.com](mailto:info@natechlighting.com)

This specification is valid as of 2017-07 and is subject to change without notice. Please confirm with the manufacturer before placing an order.  
Copyright 2014 Natech Industrie. All rights reserved.